

MECHANICAL DATA

Dimensions in mm (inches)

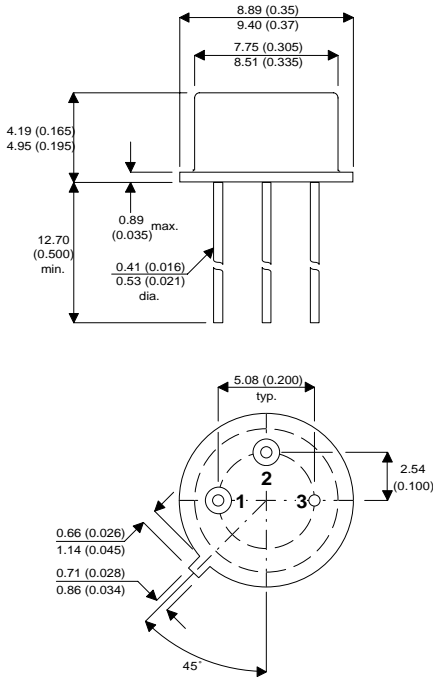

TO-39 METAL PACKAGE

Underside View

PIN 1 – Source
PIN 2 – Gate

PIN 3 – Drain
CASE – Drain

**N-CHANNEL
ENHANCEMENT MODE
MOS TRANSISTOR**

FEATURES

- Switching Regulators
- Converters
- Motor Drivers

ABSOLUTE MAXIMUM RATINGS ($T_{CASE} = 25^{\circ}C$ unless otherwise stated)

V_{DS}	Drain – Source Voltage	35V
V_{GS}	Gate – Source Voltage	$\pm 20V$
I_D	Drain Current @ $T_{CASE} = 25^{\circ}C$	1.4A
I_D	Drain Current @ $T_{CASE} = 100^{\circ}C$	1A
I_{DM}	Pulsed Drain Current *	3A
P_D	Power Dissipation @ $T_{CASE} = 25^{\circ}C$	6.25W
P_D	Power Dissipation @ $T_{CASE} = 100^{\circ}C$	2.5W
T_j	Operating Junction Temperature Range	-55 to $150^{\circ}C$
T_{stg}	Storage Temperature Range	-55 to $150^{\circ}C$
T_L	Lead Temperature ($1/16$ " from case for 10 sec.)	$300^{\circ}C$

* Pulse width limited by maximum junction temperature.

ELECTRICAL CHARACTERISTICS ($T_{CASE} = 25^{\circ}C$ unless otherwise stated)

Parameter	Test Conditions	Min.	Typ.	Max.	Unit		
STATIC CHARACTERISTICS							
$V_{(BR)DSS}$	Gate – Source Breakdown Voltage	$V_{GS} = 0V$	$I_D = 10\mu A$	35	70	V	
$V_{GS(th)}$	Gate Threshold Voltage	$V_{DS} = V_{GS}$	$I_D = 1mA$	0.8	1.6		2
I_{GSS}	Gate – Body Leakage Current	$V_{GS} = \pm 15V$ $V_{DS} = 0V$	$T_{CASE} = 125^{\circ}C$			± 100 ± 500	nA
I_{DSS}	Zero Gate Voltage Drain Current	$V_{DS} = 90V$ $V_{DS} = 72V$	$V_{GS} = 0V$ $V_{GS} = 0V$ $T_{CASE} = 125^{\circ}C$			10 500	μA
$I_{D(on)*}$	On–State Drain Current	$V_{DS} = 15V$	$V_{GS} = 10V$	1.5	1.8		A
$R_{DS(on)*}$	Drain – Source On Resistance	$V_{GS} = 5V$ $V_{GS} = 10V$ $I_D = 1A$	$I_D = 0.3A$ $T_{CASE} = 125^{\circ}C$		1.8 1.3 2.6	5 1.8 3.6	Ω
$V_{DS(on)*}$	Drain – Source On Voltage	$V_{GS} = 5V$ $V_{GS} = 10V$ $I_D = 1A$	$I_D = 0.3A$ $T_{CASE} = 125^{\circ}C$		0.54 1.3 2.6	1.5 1.8 3.6	V
g_{FS*}	Forward Transconductance	$V_{DS} = 10V$	$I_D = 0.5A$	170	350		ms
g_{OS*}	Common Source Output Conductance	$V_{DS} = 10V$	$I_D = 0.1A$		1100		μs
DYNAMIC CHARACTERISTICS							
$R_{DS(on)}$	Small Signal Drain – Source On Resistance	$V_{GS} = 10V$ $f = 1kHz$	$I_D = 1A$		1.3	1.8	Ω
C_{ds}	Drain – Source Capacitance	$V_{DS} = 24V$ $V_{GS} = 0V$ $f = 1MHz$			30	40	pF
C_{iss}	Input Capacitance				35	50	
C_{oss}	Output Capacitance				28	40	
C_{rss}	Reverse Transfer Capacitance				2	10	
SWITCHING CHARACTERISTICS							
t_{ON}	Turn–On Time	$V_{DD} = 25V$ $R_L = 23\Omega$	$V_{GEN} = 10V$ $R_G = 25\Omega$		8	10	ns
t_{OFF}	Turn–Off Time	$I_D = 1A$			9	10	

* Pulse Test: $t_p \leq 80 \mu s$, $\delta \leq 1\%$